

STECHNICS

User Manual

LED MOVING HEAD LIGHT

LEADER 1200 WP

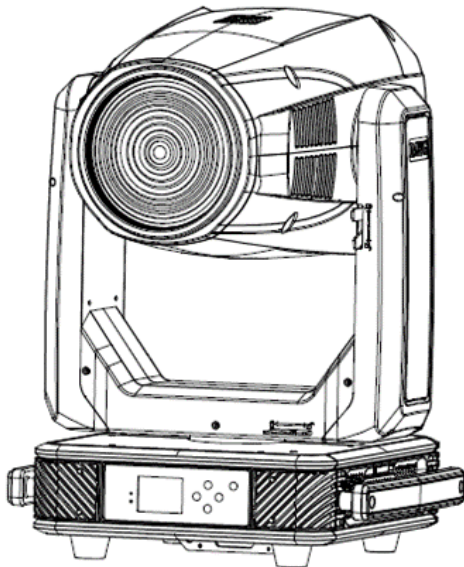

 МУЗЦЕНТР
МУЗЫКАЛЬНОЕ ОБОРУДОВАНИЕ

<https://muzcentre.ru/>

CONTENT

1. SAFETY GUIDE.....	1
2. TECHNICAL SPECIFICATION	2
2.1 LIGHT SOURCE	2
2.2 XY MOVEMENT	3
2.3 COLOR	3
2.4 SPECIFICATION	3
2.5 DISPLAY	4
2.6 SOFTWARE	4
2.7 OTHER FUNCTIONS	4
2.8 COOLING SYSTEM	4
2.9 POWER SUPPLY	4
2.10 SIZE&WEIGHT	5
2.11 PHOTOMETRIC DIAGRAM	5
3. HOW TO SET FIXTURE.....	6
3.1 CONTROL PANEL	6
3.2 MAIN FUNCTION.....	7
3.3 MOTOR OFFSET ADJUSTMENT.....	9
4. LED.....	11
5.DMX SETTING.....	11
5.1 DMX CONNECTION	11
5.2 ADDRESS CODE SETTING.....	12

5.3 DMX CHANNEL CHART	13
6. TROUBLESHOOTING	15
7. EQUIPMENT CLEANING	15
8. SPARE PARTS	16

1. SAFETY GUIDE



Please read this manual carefully, it includes Important information such as installation, use and maintenance.

PAY ATTENTION

Please save this manual as a basis for future consultation, if you sell this product to other users, please make sure they also get this manual.

Notice:

The equipment is well-packaged when shipped from the factory. Please follow the user manual for operation. Human failures are not covered by the warranty.

- Before using, please open it and check carefully to ensure that there is no damage caused by transportation.

- This fixture is only suitable for indoor dry place.

- The installation and operation of fixtures should be carried out by professionals.

- Do not let children operate the machine.

- Use safety ropes when fixing the device, and hold the bottom when moving the fixture.

- The equipment must be installed in a well-ventilated place, at least 50 cm from the adjacent surface.

- Make sure the ventilation holes are unobstructed to avoid overheating when the fixture is running.

- Before operation, ensure that the power supply voltage matches the equipment.

- Please ground the conductor to prevent electric shock.

- Do not operate the fixture in an environment above 40°C.

- It is forbidden to connect the fixture directly to the dimming equipment.

- A small amount of smoke or odor may appear when the new fixture works, and it will disappear after 15 minutes of operation.

- Do not place combustible objects beside the fixtures during operation.

- Please carefully check whether the power cord is damaged before turning on the fixture, and replace it immediately if it is damaged.

- The surface temperature can reach 85°C when the fixture is in operation, please do not touch it with bare hands.

- Avoid conductive objects such as flammable liquid, water or metal to enter the fixture to avoid electric shock or fire. If some objects enter the fixture, please cut off the power immediately

- Avoid operating in dirty and dusty environments. and clean , maintain the fixtures regularly.

- It is forbidden to touch the wire when the fixture is running to prevent electric shock.
- Avoid entanglement of the power cord and other wires.
- The distance between the fixture and the illuminated surface should be greater than 5 meters.
- Disconnect the power before replacing the fuse or bulb.
- Use the same model when replacing fuses or bulbs.
- There is a serious operation failure, please stop using it immediately.
- Please do not turn on the fixture frequently, and turn on the fixture at least every 30 seconds.
- Please replace the fixture housing, lens or ultraviolet filter in time when there is obvious damage.
- There are no available parts inside the fixture, please do not open the fixture shell without permission.
- Do not operate the machine by yourself. Operation by non-professionals will cause damage to the device or malfunction of the device. For repairs, please contact the nearest authorized service center.
- Please cut off the power when the fixture is not used for a long time or maintenance.
- When you need to transport again, please use the original packaging material.
- To avoid fire or electric shock, do not expose the fixture to rain or wet areas.
- Do not look directly when the fixture is running.

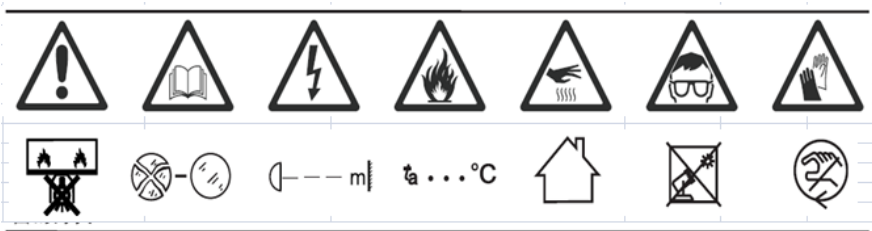

2. TECHNICAL SPECIFICATION

2.1 LIGHT SOURCE

LED type: High Power 1050W White LED

CCT: 8000K / 6000K

LED life span: 20,000hrs

CRI: Standard CRI≥70,Hi CRI≥90

2.2 XY MOVEMENT

Horizontal scan:540° (16 bit Precision scan)

Vertical scan:270° (16 bit Precision scan)

The advanced scanning system is faster, more stable, quieter, and has an automatic error-correcting reset function.

2.3 COLOR

Smooth and Sophisticated color mix system providing CMY+CTO color mixing(2700K-5500K/7000K);

2 colour wheel:6 saturated colour filters+ open, Rainbow effect with bi-directional and variable speeds.

2.4 SPECIFICATION

Channel mode: 13/19 Standard DMX512 Channel;

Focus: Electronic focus, ultra-smooth adjustment of focus.

Strobe: The frequency can reach up to 25Hz, and random strobe and pulse strobe can be selected.

Dimming: 0~100% linear dimming, 4 dimming curves available.

Zoom:10°~ 63°linear zoom

2.5 DISPLAY

Touch the color LCD display: with rechargeable battery, you can enter the menu to set the address code and make other settings without powering on; when power is off, press the "BAT SW" key on the display panel for 3 seconds to enter setting DMX address and Other menu functions, automatically cut off in 5 seconds when not in operation. Automatically charge the battery when power on.

2.6 SOFTWARE

Can change DMX address code, fixture reset, channel control mode conversion and other functions from the console; display the fixture usage time, convenient for customers to know the fixture usage in time.

2.7 OTHER FUNCTIONS

Input signal isolation protection function to ensure stable signal transmission without interference.

2.7.1 RDM FUNCTION

DMX Signal input/output: XLR3/5pin RJ45 and USB connector socket.

2.7.2 Wireless function (optional)

2.8 Cooling System

Advanced cooling system based on fan heat dissipation;

The light source fan starts to work only when the light source temperature > 40°C , and the fan speed is adjusted according to the temperature.

Safety protection against over-heating.

2.9 POWER SUPPLY

AC100~240v,50/60Hz

Power 1200 W

2.10 SIZE&WEIGHT

Body Size: 470*432*809 mm

Net Weight: 42.5kg(Including Clamp)

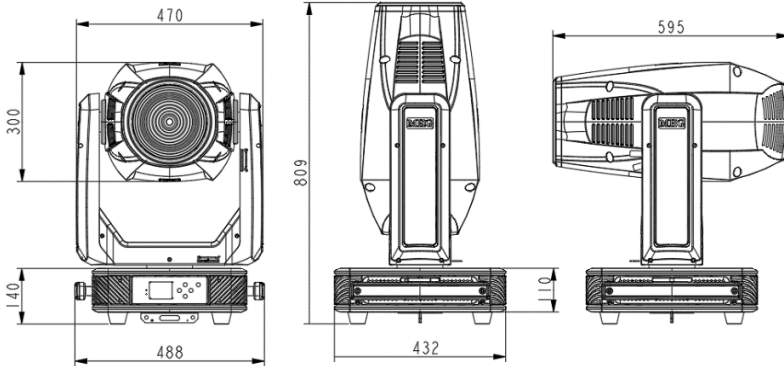

3、 HOW TO SET FIXTURE

3.1 CONTROL PANEL

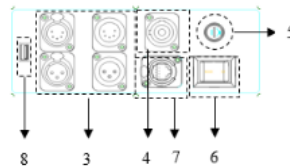
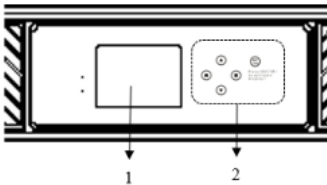

1. LCD display: Function menu;

2. Operate Button;

	MENU: choose the Function
	ENTER: confirm the Function
	UP: back to previous Options
	DOWN: next Options
	Battery button

3. DMX In/Out
4. Connect main power
5. Fuse(T 15A)RJ45
6. Power switch: power
On/Off
7. RJ45 Internet connector
8. USB connector

3.2 MAIN FUNCTION

Press **MENU** with 3s (3 seconds) into Menu choose mode to choose what you want, press **ENTER** to confirm the function, the LCD display will flash. Then press **UP/DOWN** to choose the function, press **ENTER** to confirm it. Press **MENU** for back to previous menu, or wait for 1 minute for back to main menu.

Main Functions:

DMX	DMX Address	1-512
	DMX Channel Mode	Mode1(13)
		Mode2(19)
	DMX State	Blackout
Hold		
	View DMX Value	---
SET.	Pan Inverse	Yes/No
	Tilt Inverse	Yes/No
	P/T Feedback	Yes/No
	Dimmer Curve	Liner
Square law		

		Inv SQ law
		S Curve
	Dimmer Speed	Fast
		Smooth
DISP	Display Inverse	Yes/No
	Backlight Switch	On/Off
	Backlight Intensity	1-10
	Temperature Unit	°C/°F
	Language	English/Chinese
TEST	Auto Test	-
	Manual Test	-
INFO.	Fixture use time	-
	Temperature	-
	Fixture Name	
	CPU Version	-
RSET	Pan/Tilt	Yes/No
	Effect	Yes/No
	All Motor	Yes/No
SPEC.	Factory Setting	Yes/No

Note:

Dimmer Modes:

Dimmer Modes

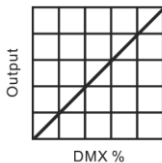

Optically Linear

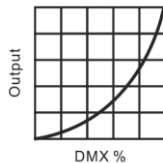

Square Law

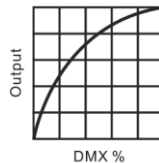

Inverse Square Law

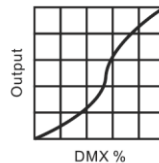

S-curve

Mode1(Liner): As the DMX value increases, the light intensity tends to be linear;

Mode2(Square law): The light intensity is controlled to be finer at low values and thicker at high values;

Mode3(Inv SQ law): The light intensity is controlled to be thicker at low values and thinner at high values;

Mode4(S Curve): The light intensity is controlled to be finer at low and high values, and thicker at intermediate values.

(2) Test function description:

1) When selecting the demo program, the machine will run the built-in program to test horizontal, vertical, color, gobo wheel, gobo wheel rotation, strobe, dimming, prism, prism rotation, frost, focus, etc. Press the MENU button to return to the previous menu.

2) When selecting manual test, the current channel will be displayed on the display screen, and the machine will run according to the value of the channel. After exiting the manual test menu, all channel values will become zero.

3.3 Motor offset adjustment

Press the MENU button to enter the menu mode, then press the ENTER button for about 3 seconds to enter the initial setting menu to adjust the initial position of each motor. Press the ENTER button to confirm. Use the UP/DOWN button to select a sub-menu, press the ENTER button to save and automatically return to the previous menu. Press the MENU button to exit.

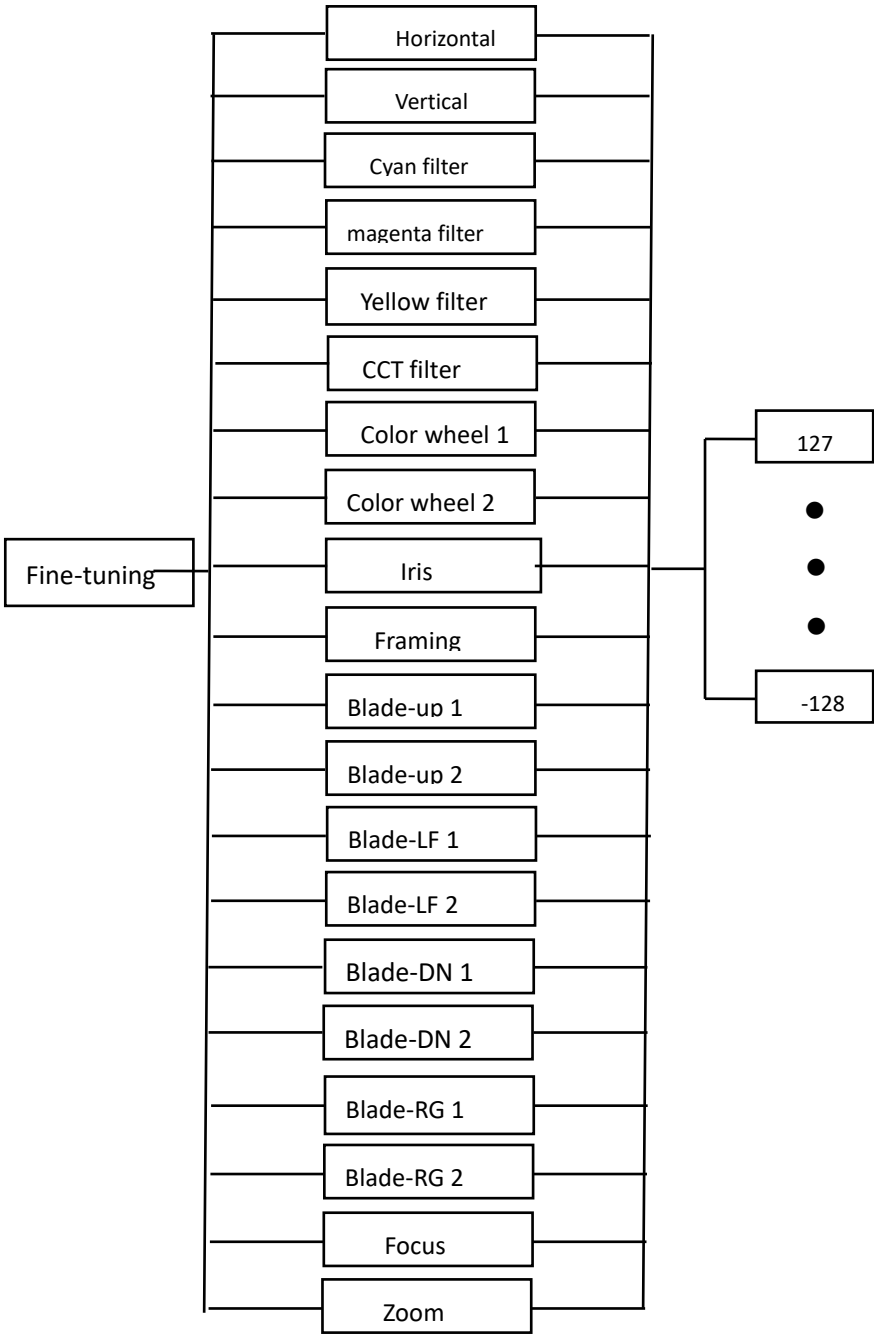

Horizontal

Enter the initial setting menu, select horizontal, press the ENTER button to confirm, the current position will be displayed on the display, use the UP/DOWN button to adjust the horizontal initial position (-128-127), press the ENTER button to save. Press the MENU button to exit.

Vertical

Enter the initial setting menu, select Vertical, press the ENTER button to confirm, the current position will be displayed on the display, use the UP/DOWN button to adjust the vertical initial position (-128-127), press the ENTER button to save. Press the MENU button to exit.

Cyan filter

Enter the initial setting menu, select the cyan filter, press the ENTER button to confirm, the current position will be displayed on the display, use the UP/DOWN button to adjust the initial position of the cyan filter (-128-127), press the ENTER button to save . Press the MENU button to exit.

Magenta filter

Enter the initial setting menu, select the rose red filter, press the ENTER button to confirm, the current position will be displayed on the display, use the UP/DOWN button to adjust the initial position of the rose red filter (-128-127), press the ENTER button to save . Press the MENU button to exit.

Yellow filter

Enter the initial setting menu, select yellow filter, press the ENTER button to confirm, the current position will be displayed on the display, use the UP/DOWN button to adjust the initial position of the yellow filter (-128-127), press the ENTER button to save. Press the MENU button to exit.

CCT filter

Enter the initial setting menu, select color temperature, press the ENTER button to confirm, the current position will be displayed on the display, use the UP/DOWN

button to adjust the color temperature initial position (-128-127), press the ENTER button to save. Press the MENU button to exit.

Color wheel 1

Enter the initial setting menu, select the color wheel 1, press the ENTER button to confirm, the current position will be displayed on the display, use the UP/DOWN button to adjust the initial position of the color wheel (-128-127), press the ENTER button to save. Press the MENU button to exit.

Color wheel 2

Enter the initial setting menu, select the color wheel 2, press the ENTER button to confirm, the current position will be displayed on the display, use the UP/DOWN button to adjust the initial position of the color wheel (-128-127), press the ENTER button to save. Press the MENU button to exit.

Iris

Enter the initial setting menu, select aperture, press the ENTER button to confirm, the current position will be displayed on the screen, use the UP/DOWN button to adjust the initial position of the aperture (-128-127), press the ENTER button to save. Press the MENU button to exit.

Framing rotation

Enter the initial setting menu, select Framing rotation, press the ENTER button to confirm, the current position will be displayed on the screen, use the UP/DOWN button to adjust the initial position of the Framing rotation (-128-127), press the ENTER button to save. Press the MENU button to exit.

Blade-UP 1

Enter the initial setting menu, select Blade-up1, press the ENTER button to confirm, the current position will be displayed on the screen, use the UP/DOWN button to adjust the initial position of Blade-up1 (0-255), press the ENTER button to save. Press the MENU button to exit.

Blade-UP 2

Enter the initial setting menu, select Blade-up2, press the ENTER button to confirm, the current position will be displayed on the screen, use the UP/DOWN button to adjust the initial position of Blade-up2 (0-255), press the ENTER button to save. Press the MENU button to exit.

Blade-LF 1

Enter the initial setting menu, select Blade-LF1, press the ENTER button to confirm, the current position will be displayed on the screen, use the UP/DOWN button to adjust the initial position of Blade-LF1 (0-255), press the ENTER button to save. Press the MENU button to exit.

Blade-LF 2

Enter the initial setting menu, select Blade-LF 2, press the ENTER button to confirm, the current position will be displayed on the screen, use the UP/DOWN button to adjust the initial position of Blade-LF 2 (0-255), press the ENTER button to save. Press the MENU button to exit.

Blade-DN 1

Enter the initial setting menu, select Blade-DN1, press the ENTER button to confirm, the current position will be displayed on the screen, use the UP/DOWN button to adjust the initial position of Blade-DN 1 (0-255), press the ENTER button to save. Press the MENU button to exit.

Blade-DN 2

Enter the initial setting menu, select Blade-DN 2, press the ENTER button to confirm, the current position will be displayed on the screen, use the UP/DOWN button to adjust the initial position of Blade-DN 2 (0-255), press the ENTER button to save. Press the MENU button to exit.

Blade-RG 1

Enter the initial setting menu, select Blade-RG1, press the ENTER button to confirm, the current position will be displayed on the screen, use the UP/DOWN button to adjust the initial position of Blade-RG1 (0-255), press the ENTER button to save.

Press the MENU button to exit.

Blade-RG 2

Enter the initial setting menu, select Blade-RG 2, press the ENTER button to confirm, the current position will be displayed on the screen, use the UP/DOWN button to adjust the initial position of Blade-RG 2 (0-255), press the ENTER button to save. Press the MENU button to exit.

Focus

Enter the initial setting menu, select focus, press the ENTER button to confirm, the current position will be displayed on the screen, use the UP/DOWN button to adjust the initial focus position (-128-127), press the ENTER button to save. Press the MENU button to exit.

Zoom

Enter the initial setting menu, select Zoom, press the ENTER button to confirm, the current position will be displayed on the screen, use the UP/DOWN button to adjust the initial zoom position (-128-127), press the ENTER button to save. Press the MENU button to exit.

4.3 LED

- Light source: 1050W LED Modular
- Color Temperature: 8000K (Standard)
/6500K(High CRI)
- Work life: 20,000HLED
- CRI: Standard \geq 70; High CRI \geq 90
- Spot uniform: \geq 90%

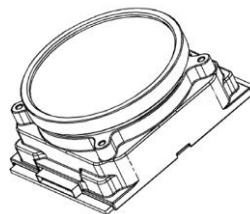

5、DMX Setting

5.1 DMX Connection

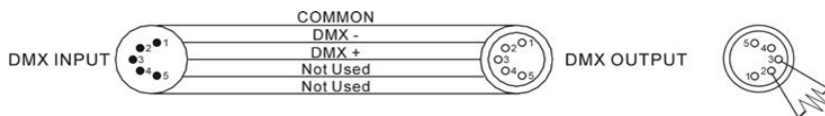

- 1) In order to reduce signal errors and avoid signal weakening and interference during transmission, a 120 OHM 1/4W resistor can be added between the 2 and 3 cores of the DMX output terminal of the last machine.
- 2) Connect the fixture with XLR cable, one end is connected to the output port of the fixture, and the other end is connected to the input port of the next fixture. XLR signal lines can only be used in series, not in parallel. DMX512 signal transmission speed is very fast. Damage to the signal line, weak welding, poor contact, etc., will affect the signal transmission and cause the system to shut down.
- 3) When power supply of a certain unit is disconnected, the connection of DMX output and input is bypassed in order to maintain the connection of DMX line.
- 4) Each fixture must have an address code, which can receive the information sent by the console, and the range is between 0-511 (usually 0&1 and 1 are the same).
- 5) The terminal of the DMX512 system needs to be equipped with a terminator to reduce signal transmission errors.
- 6) 3-pin XLR connectors are more common than 5-pin XLR:
- 7) 3-pin XLR: PIN 1: GND, PIN 2: negative signal, PIN 3: positive signal.
- 8) 5-pin XLR: PIN 1: GND, PIN 2: negative signal, PIN 3: positive signal, PIN4/PIN5: not used;

5.2 Address code setting

When using a general DMX controller to control the fixture, you need to set

the starting address (1-512) for the fixture, so that it can receive the DMX signal. Press the menu button to enter the menu mode, select the DMX function, press the ENTER button to confirm, the current address will flash on the display, then use the UP/DOWN buttons to select the address code (1-3512), press the ENTER button to save. Press the MENU button to return to the previous menu or wait one minute to automatically exit the menu mode. Please refer to the chart below to set the address codes of the first 4 fixtures:

Channel	Light 1	Light 2	Light 3	Light 4
Mode	Address code	Address code	Address code	Address code
30 channel	1	31	61	91
32 channel	1	33	65	97

5.3 DMX512 Channels

23ch	29ch	Value	Function
21	1	(0-255)	Pan
	2	(0-255)	Fine-tuning for Pan
22	3	(0-255)	Tilt
	4	(0-255)	Tilt speed
	5	(0-255)	Pan/Tilt speed: fast → slow
23	6	(0-29) (30-39) (40-49) (50-59) (60-69) (70-79)	Special function None Dimming curve square Dimming curve inverse square Dimming curve linear Dimming curve S shape Scan with shading

		(80-89) (90-99) (100-109) (110-169) (170-179) (180-189) (190-199) (200-209) (210-219) (220-229) (230-255)	Scanning without shading Color wheel positioning with shading Color wheel positioning without shading None Dimming speed built-in Fast dimming speed Smooth dimming speed All reset Fixture head reset X/Y reset None
1	7	(0-15) (16-30) (31-135) (136-145) (146-175) (176-185) (186-215) (216-225) (226-245) (246-255)	Strobe Strobe off Strobe on Strobe: slow → fast Strobe on Strobe fast closing slow opening: slow → fast Strobe on Strobe fast closing slow opening: slow → fast Strobe on Random strobe: slow → fast Strobe on
2	8	(0-255)	Dimming
	9	(0-255)	Dimming fine-tuning
3	10	(0-255)	Cyan

4	11	(0-255)	Magenta
5	12	(0-255)	Yellow
6	13	(0-255)	CTO
7	14	(0-131) (132-141) (142-151) (152-161) (162-171) (172-181) (182-191) (192-222) (223-224) (225-255)	Color wheel 1 Color moves linearly Color-1 Color-2 Color-3 Color-4 Color-5 Color-6 Clockwise rotation: fast → slow Stop Counterclockwise rotation: fast → slow
8	15	(0-131) (132-141) (142-151) (152-161) (162-171) (172-181) (182-191) (192-222) (223-224) (225-255)	Color wheel 2 Color moves linearly Color-1 Color-2 Color-3 Color-4 Color-5 Color-6 Clockwise rotation: fast → slow Stop Counterclockwise rotation: fast → slow
18	16	(0-255)	Iris: big → small
19	17	(0-255)	Focus

	18	(0-255)	Focus fine tuning
20	19	(0-255)	Zoom
	20	(0-255)	Zoom fine tuning
9	21	(0-255)	Framing rotating (0° -90°)
10	22	(0-255)	Blade-UP1(%-100%)
11	23	(0-255)	Blade-UP2 (% -100%)
12	24	(0-255)	Blade-LF 1 (% -100%)
13	25	(0-255)	Blade-LF2 (% -100%)
14	26	(0-255)	Blade-DN 1 (% -100%)
15	27	(0-255)	Blade-DN 2 (% -100%)
16	28	(0-255)	Blade-RG 1 (% -100%)
17	29	(0-255)	Blade-RG 2 (% -100%)

6. Trouble shooting

The following are some of the problems that often occur in operation. There are some suggestions for troubleshooting.

A. The fixture cannot run, there is no light, and the fan is damaged.

- 1) Check the power connection and whether the fuse is intact. Check the voltage.
- 2) Check the indicator light of the switching power supply.

B. Uncontrolled by the console.

- 1) The indicator light must be red, if not, check the DMX signal connector and signal line to see if the connection is correct.
- 2) If the DMX indicator is red, but there is no response to the control channel, check whether the address code is set correctly.
- 3) If the DMX signal transmission is intermittent, check whether the XLR socket and the signal line are well connected.
- 4) Try to use another controller.
- 5) Check if the distance between the DMX signal line and the high-voltage line is too close, otherwise it will damage or interfere with the signal circuit.

C. A channel fails

- 1) The stepping motor may be damaged, and the motor lead may be broken.
- 2) The drive circuit of the motor may be faulty.

7. Equipment cleaning

The inside and outside of the lens must be wiped frequently to make the lighting effect better. The frequency of wiping depends on the environment. Humid, smoky, and particularly dirty environments are likely to accumulate dust on the lens. ☒

Use soft linen cloth and special glass wiper. ☒

Dry the parts carefully.

Wipe the outside of the lens at least every 30 days.

8. Spare parts

- 1) 1pcs power cable
- 2) 1pcs signal connection line
- 3) 1pcs insurance rope
- 4) 1pcs user manual

